

## Solar Radiation and Temperature Node

- ▶ **Low Power Wireless Sensor Node.**
- ▶ **Compatible with The Things Network LoRaWAN**
- ▶ **EKO ML-01 Si-Pyranometer input**
- ▶ **Long battery life.**
- ▶ **Tough weatherproof enclosure**
- ▶ **Data and status information displayed on the rpr-LoT dashboard.**
- ▶ **Plug-in sensors.**



## Overview

The rpr-LoT-SR02 is a battery powered Solar Radiation and temperature sensor node. suitable for use with the EKO ML01 Si Pyranometer and rpr-LoT temperature probes. It communicates using long range radio compatible with LoRaWAN and the Things Network. The low power electronics are housed in a rugged IP67 enclosure suitable for outdoor and industrial applications. A sealed connector is used for the connection to the sensor.

Data is stored on the rpr-LoT cloud and or the RPR WeatherFile.com cloud for long-term storage and access. Readings and status information is displayed on the rpr-LoT dashboard (subscription required for enhanced features). The dashboard enables data from several nodes to be plotted and displayed in a flexible manner to suit the user.

The unit uses a long life 4000mAh A size Lithium Thionyl Chloride (LiSOCl<sub>2</sub>) battery which is user replaceable.

## Applications

The rpr-LoT-SR02 has a wide range of applications where high-quality solar irradiance and temperature measurements are required.

- ✓ PV performance monitoring
- ✓ Meteorology
- ✓ Precision Agriculture
- ✓ Sports grounds
- ✓ Working conditions
- ✓ Education and research projects

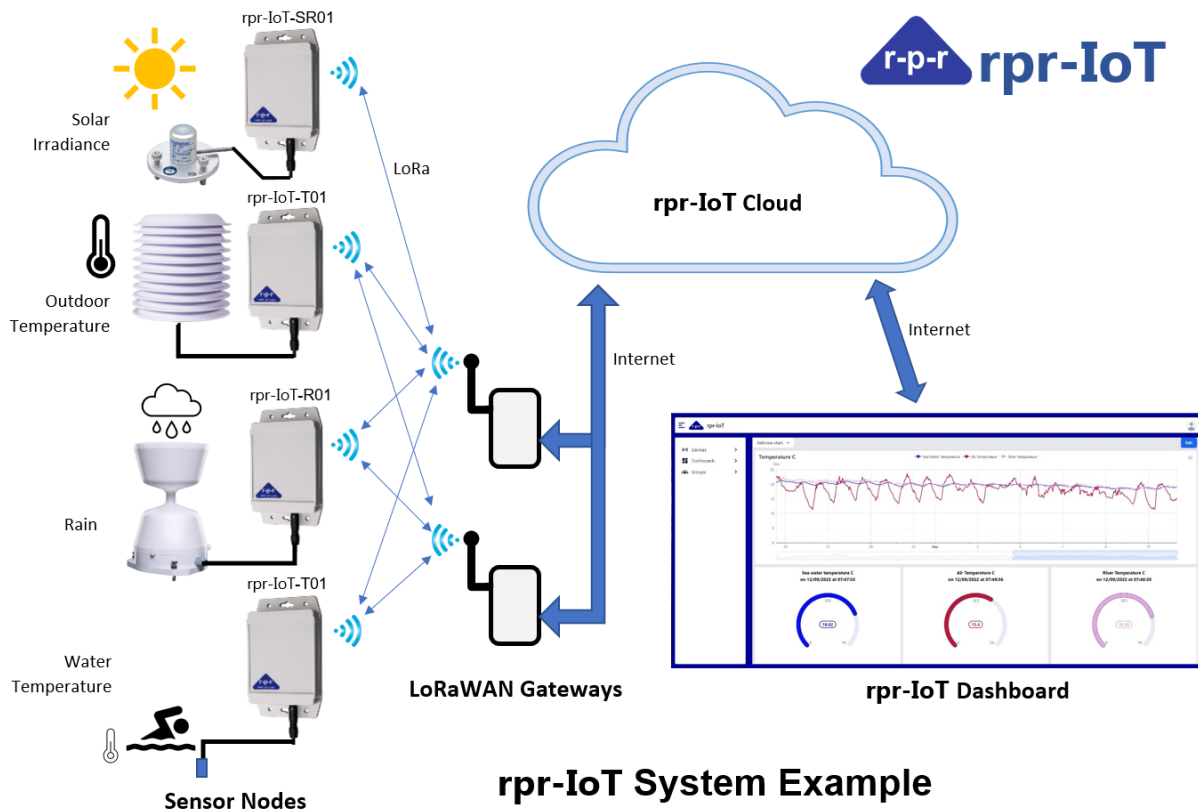

## IoT LoRaWAN

rpr-IoT sensor nodes are LoRaWAN compatible class A devices which ensure secure interoperability between the sensor node, gateways and the cloud. They communicate using the LoRa wireless modulation technique based on chirp spread spectrum technology which allows data transfer over long distances at a very low power. It is possible for a single gateway to connect to many nodes and/or a node to connect to multiple gateways over a large area. Nodes can be spread over several km line of sight in open land. To help with deployment and monitoring of an IoT application the received signal strength and signal to noise ratio for each node is available on rpr-IoT dashboard. By default, the rpr-IoT sensor nodes use the Things Network. If operation with other networks is required, please contact Richard Paul Russell Ltd.

## Simple to Use

The rpr-IoT-SR02 has been designed to be simple to use. It will automatically, if there is a suitable gateway within range, join the LoRaWAN Things Network when the sensor is plugged in and then after this regularly send data to the users rpr-IoT dashboard.

## Message interval

The rpr-IoT-SR02 will adhere to the Things Network's public community network fair use policy and adjust the minimum uplink message interval depending on the Data rate / Spreading Factor as shown in the following table:

Data rate	Spreading factor	Minimum up message interval
DR5	SF7	3 minutes
DR4	SF8	6 minutes
DR3	SF9	10 minutes
DR2	SF10	20 minutes
DR1	SF11	45 minutes
DR0	SF12	90 minutes

The spreading factor is determined by the Adaptive Data Rate (ADR) mechanism implemented in The Things Stack which is based on the signal to noise ratio (snr) of the received signal. When first switched on the node will join with a spreading factor of 12. To optimise battery usage the uplink message interval can be set to a longer value.

## Data Security

Advanced Encryption Standard (AES) 128-bit algorithms are used to provide two layers of cryptography, to the network server and end-to-end to the application server.

## Dashboard

The rpr-IoT dashboard is user configurable to display data from multiple sensor nodes. Tiles can be added which display data in different formats, for example: line plots, bar graphs, dials or graphically on a map or plan. Individual tiles can be defined and positioned by the user to suit their needs. Sensors can be given names applicable to their application.

The dashboard allows status information including battery state, signal strength, signal to noise ratio, and gateways to be monitored. Commands to set

the uplink message interval can be sent from the dashboard.

## RPR Products

Richard Paul Russell Ltd offers a range of IoT systems, weather instrumentation and data loggers. Please contact us for more information.

## Contact Us

e-mail: [sales@r-p-r.co.uk](mailto:sales@r-p-r.co.uk)

Tel: +44 (0)1590 641223

Website: [www.r-p-r.co.uk](http://www.r-p-r.co.uk)

Richard Paul Russell Ltd  
The Lodge, Unit 1 Barnes Farm Business Park  
Barnes Lane, Milford on Sea, SO41 0AP UK

## Specification

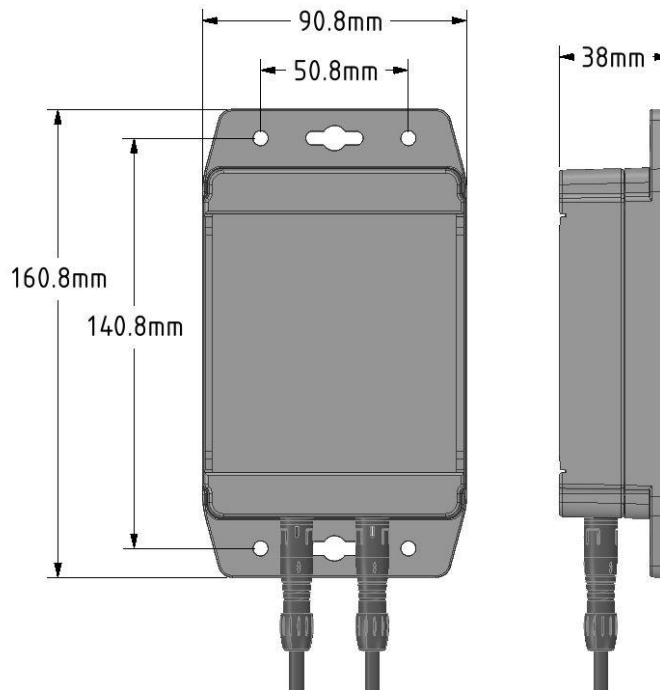

Physical	
Enclosure dimensions including flanges but excluding sensor	160.8mm x 90.8mm x 38 mm
Mounting holes	4 off 5 mm dia. 140.8 mm x 50.8 mm
Mounting key holes	2 off 8.5 mm dia. 4.6 mm slot, 140.8 spacing
Flange thickness	6.5 mm
Enclosure material	Polycarbonate, Light Gray (RAL 7035)
Enclosure flammability rating	UL94 5VA @ 3mm
Weight without sensors	255g

<b>Sensor Inputs (1)</b>	rpr-IoT-ML01 EKO ML-01 Class C Si-Pyranometer rpr-IoT-TP01 Temperature Probe s/s 1m
Solar irradiance range	2 to 2000 W/m <sup>2</sup>
Solar irradiance resolution	1 W/m <sup>2</sup>
Temperature accuracy	± 0.5°C (-10°C to +85°C)
<b>Wireless/network Connectivity</b>	
Frequency band	863-870 MHz
LoRa Channel	EU868
Networking Protocol	LoRaWAN, Class A
Aerial	Internal Meandering Monopole circuit board mounted
Uplink Message Interval	By default, the interval is dependent on the Spreading Factor and The Things Network's public community network Fair Use Policy.
Range	Up to 10km Line of sight dependent on environment
<b>Power</b>	
Battery type	A size Lithium Thionyl Chloride (LiSOCl <sub>2</sub> )
Nominal Battery Capacity	4000mAh
Nominal Battery Voltage	3.6V
Nominal Battery Life	>1 year (SF7, message interval >30 minutes)
<b>Environmental</b>	
Temperature range	Operating: -10°C to +60°C, Storage: -40°C to +70°C
Relative Humidity	0% to 100%
Enclosure protection	IP67
Compliance	UKCA, CE

(1) See individual datasheets for sensor specifications.

The manufacturer reserves the right to amend the specification and therefore the information in this document may be subject to change.



rpr-IoT-ML01 EKO ML-01 Class C Si-Pyranometer

## Order Codes



Order Code	Description
rpr-IoT-SR02	Solar Radiation and Temperature Node (without sensors)
rpr-IoT-ML01	Si-Pyranometer (Class C) with 5m cable & connector
rpr-IoT-TP01	Temperature Probe s/s 1m
WS-EML-S-860-050	EML SS5/12 Non-Aspirated Sensor Screen & bracket
rpr-IoT-C5B	Connector, 5-way, blue, for Pyranometer
rpr-IoT-BCAP	Connector blanking cap
rpr-IoT-BAT-A	Lithium Thionyl Chloride (LiSOCl <sub>2</sub> ) A size battery
rpr-IoT-GW-868	LoRaWAN indoor gateway EU868